

Model 446 / 446M11

Parallel Opposed Thermally Compensated IR Detector with Internal Amplifier



Manufactured under one or more of the following U.S. patents: 3,839,640 - 4,218,620 - 4,326,663 - 4,384,207 - 4,437,003 - 4,441,023 - 4,868,390

The **Model 446 / 446M11** is a parallel opposed, thermally compensated lithium tantalate high gain detector with an internal operational amplifier and precision voltage reference. This detector offers high performance detection capability, with the ability to cancel thermal changes to the case. The 446M11 operates over an extended temperature range of -40 to +70°C. The operational amplifier is operated in the current mode and provides very high responsivity with a low impedance output. The internal voltage reference sets the operating point of the amplifier and provides a stable 2.50 V reference output.

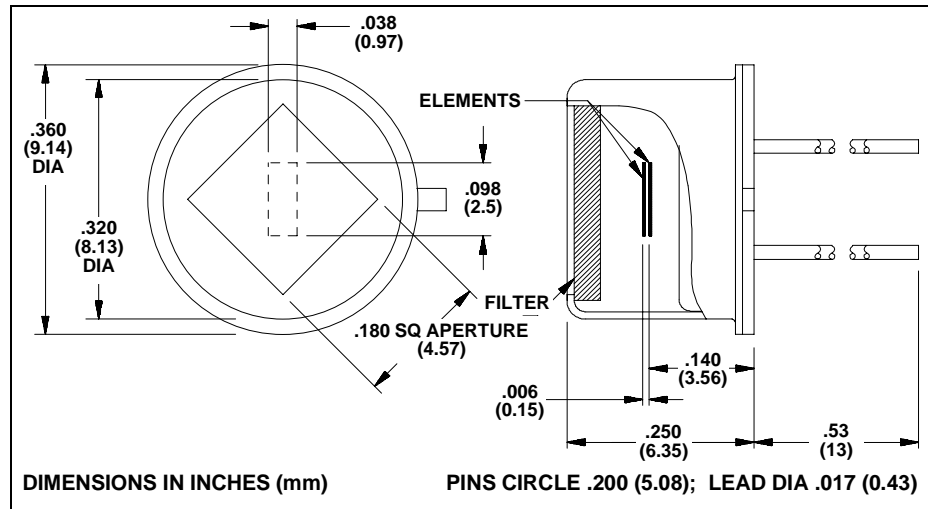

Features

- High Sensitivity and Low Noise
- Outstanding Detectivity (D^*)
- Cancellation of Case Thermal Changes
- Wide Operational Temperature Range
- Immune to RFI-EMI
- Simplified External Circuitry

Applications

- Hot Object Detection and Counting
- Industrial Control in Areas of Large Ambient Temperature Changes
- Motion Sensing
- Robotics
- Heating / AC Control
- Flame Detection

Characteristics	446 / 446M11	Unit	Test Conditions	ELTECdata Reference
Detector Type	POD			
Element Size	1.0 x 2.5	mm, each		
Optical Bandwidth	0.1 to 1,000	μm	Various Filters	101
Responsivity	(typ) 51,900 (min) 38,100	V/W	8 to 14 μm , 10 Hz	
Noise	(typ) 130	$\mu\text{Vrms}/\sqrt{\text{Hz}}$	10 Hz, 1 Hz BW	
NEP	(typ) 2.87×10^{-9}	$\text{W}/\sqrt{\text{Hz}}$	8 to 14 μm , 10 Hz, 1 Hz BW	100
D^*	(typ) 5.84×10^7	$\text{cm}\sqrt{\text{Hz}}/\text{W}$	8 to 14 μm , 10 Hz, 1 Hz BW	100
Operating Voltage	(min) 5 (max) 15	VDC	V+ to Gnd	104 (4.1.c)
Operating Current	(typ) 1.5	mA		104 (4.1.c)
Offset Voltage ¹	± 500	mV	Referenced to Pin 3	106 Section B
Reference Voltage ²	+2.50 V \pm .08	V		
Thermal Breakpoint f_T (typ)	0.20	Hz		102
Recommended Operating Temperature	0 to +70 -40 to +70	$^{\circ}\text{C}$ (446) $^{\circ}\text{C}$ (446M11)	Functional	
Storage Temperature	-55 to +125	$^{\circ}\text{C}$	$\Delta T < 50 \text{ C}/\text{min}$	
Output Load (min)	10k	Ω		
Output Protection	Short circuit protected, but DO NOT REVERSE SUPPLY POLARITY			

Characteristics at: 25°C, with -3 filter, V+ = 5VDC

Data is established on a sample basis and is believed to be representative.

¹Model 446M11 has lower offset voltage shift in temperature than Model 446.

²The internal reference voltage is accessible on Pin 3. This voltage is used to bias the internal amplifier. Offset voltage is referred to this point. This voltage provides a low drift reference to allow direct DC coupling of a subsequent comparator or A/D converter. The recommended maximum load on this pin is 100 μA (source only) to maintain electrical and thermal stability. Current loads greater than 100 μA may adversely affect performance; however, the output is short circuit protected.

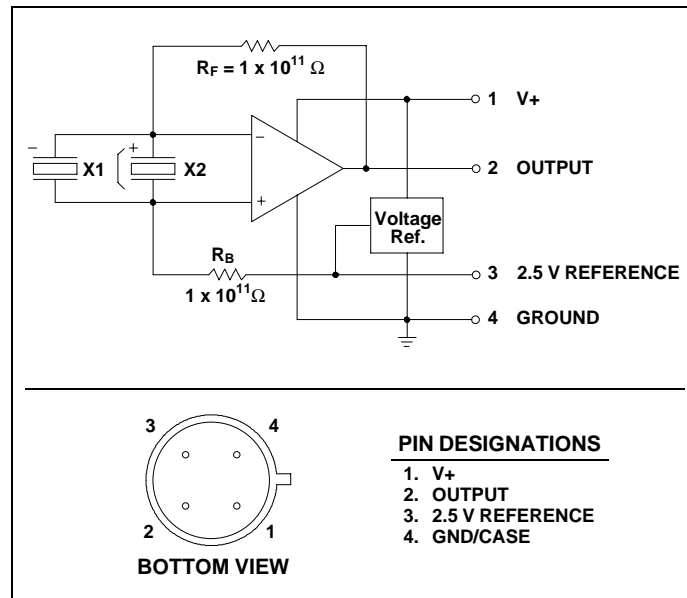
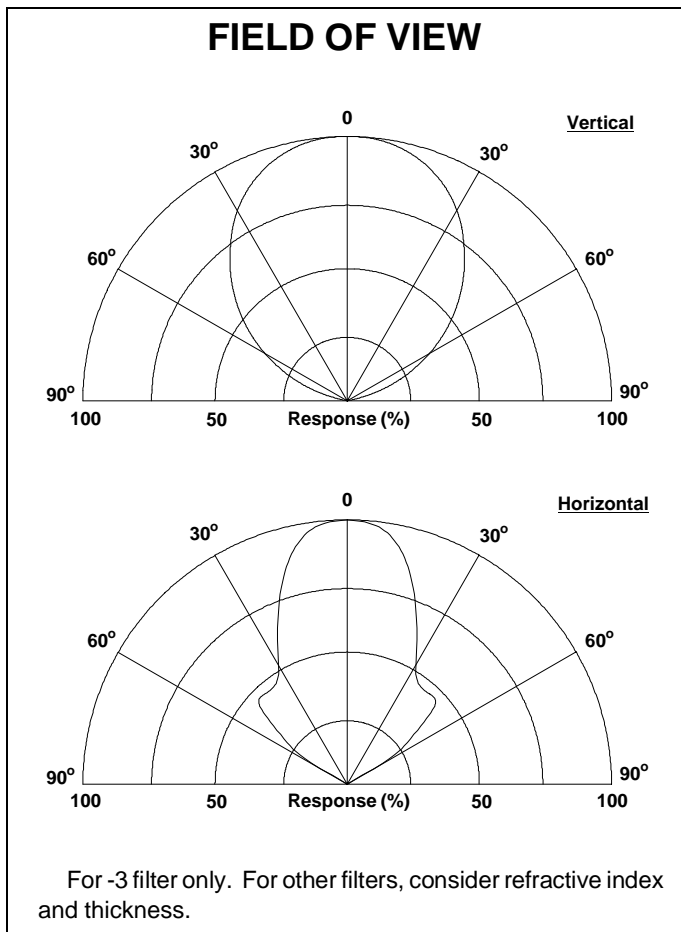

For best results, the following precautions and recommendations should be observed. (See ELTECdata #101):

Mounting: Avoid mechanical stresses on case and leads.

Soldering: Detectors must be hand soldered to minimize the chance of destroying the internal components. Avoid machine or hot air soldering. Leave a minimum lead length of .250 inch (6.35mm). When soldering to detector leads, use a heat sink between the case and leads. Beware that the new RoHS compliant solders require a higher soldering temperature making heat sinking the detector extremely important.

Static Discharge: Protect detectors from electro-static charges.

Thermal Shock: Temperature changes and rate of change must be kept to a minimum (<50C°/min.) to prevent damage.

Noise: As a resolution or lower information limit, noise is established not only by the detector. Other noise sources are:

- Radiated and conducted RF signals
- Subsequent amplification or signal conditioning stages
- Power supply noise
- Components, such as high value resistors and capacitors (tantalum and aluminum electrolytic)
- Mechanical contacts and weak solder joints
- Shock and vibration excited microphonics
- Outside thermal influences on the detector other than the desired infrared input, i.e. drafts

All of these noise sources should be considered carefully when the information signal is <10 mV.

Light Leakage: Slight sensitivity to visible light leaking through the glass-to-metal seal on the base may be observed.

Optical Design: Use of a detector with a filter in an optical system may require consideration of the image displacement toward the filter. This displacement (s) caused by the insertion of a planoparallel plate (filter thickness = t; refractive index = N) is given by $s = (t/N)(N-1)$.

Transmission Characteristics of -3 Filter (HP7)

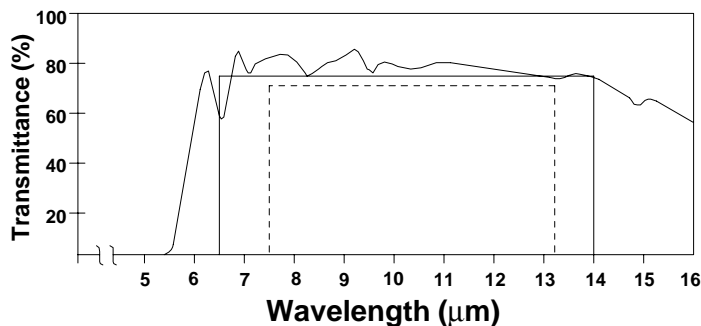

75% Transmission Average
 70% Transmission Absolute

Transmission below cutoff is <1%

For information on other standard filters available, refer to ELTECdata #101.

NOTICE: The information provided herein is believed to be reliable. However, ELTEC Instruments, Inc. assumes no responsibility for inaccuracies or omissions. Due to industry components being incorporated into ELTEC's devices and ELTEC continually striving for product improvement, specifications may change without notice.



ELTEC Instruments, Inc. P.O. Box 9610 Daytona Beach, Florida 32120-9610 U.S.A.
 Tel (USA and Canada): (800) 874-7780 Tel (Outside USA): (386) 252-0411 Fax: (386) 258-3791
 Web: www.eltecinstruments.com E-Mail: Sales@eltecinstruments.com